

Alarm 38: Low pressure

The pressure is constantly being monitored. If the pressure is 4 PSI lower than the set PSI this alarm will trigger.

This alarm is controlled by LOW PSI on the delays screen. MENU\HMI SYSTEM\DELAYS
Value range 0 – 9,999. The default is 2,000 seconds.

This alarm is not disable able.

The most common problem is with the incoming air pressure. If the incoming air pressure is lower than the sealing pressure, this alarm will occur.

On large machines, the LOW PSI delay may need to be set longer as it takes more time to achieve a stable pressure.

Proportional regulator diagnostics

If the Delay is not the problem, there could be a problem with the proportional regulator circuit. If the actual pressure states 6 PSI constantly. This indicates that WX1 is not connected to the proportional regulator.

1. Check the connections from the proportional regulator to the PLC.
2. On the HMI, Go to Pressure validation. MENU\VALIDATE\PSI. With an external pressure gauge connected to the Air Test port, go through all set pressures and verify that the actual pressure matches the gauge and the set pressures.



- a. If the external gauge and the actual pressure are not changing, set the pressure to 60 psi. With a DC voltmeter, Measure between WY1 and WY1C. There should be 6vdc.

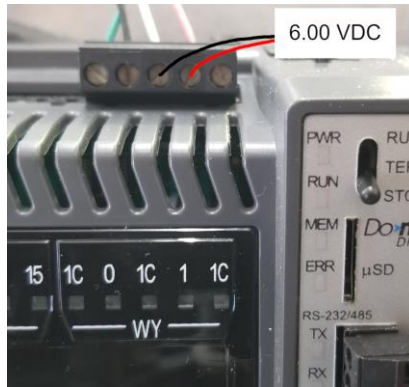

If there is 6vdc then check the connections on the terminal board.
If there is not 6vdc on the plc, disconnect WY1 and check again. If there still is no voltage the PLC will need to be replaced.
If there is voltage while being disconnected, this indicates a possible short. Check the connections on the terminal board.

- b. If the external gauge is changing but the Actual pressure is not, set the pressure to 60 psi. With a DC voltmeter, Measure between WX1 and WX1C. There should be 6vdc.

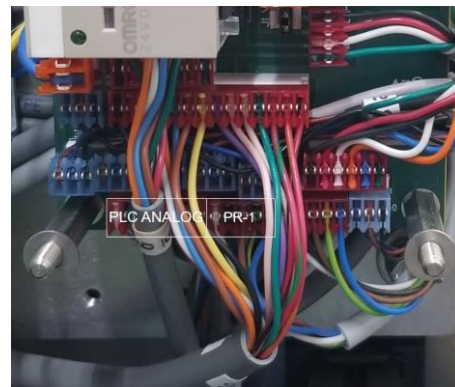
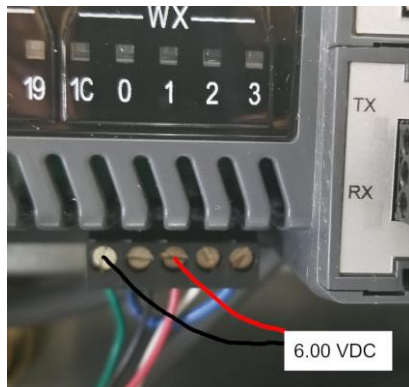

If there is 6vdc on the PLC, either the black connector is bad, or the PLC needs to be replaced.
If there is not 6vdc on the plc, there is a bad connection between the PLC and proportional regulator. Or the proportional regulator is bad.

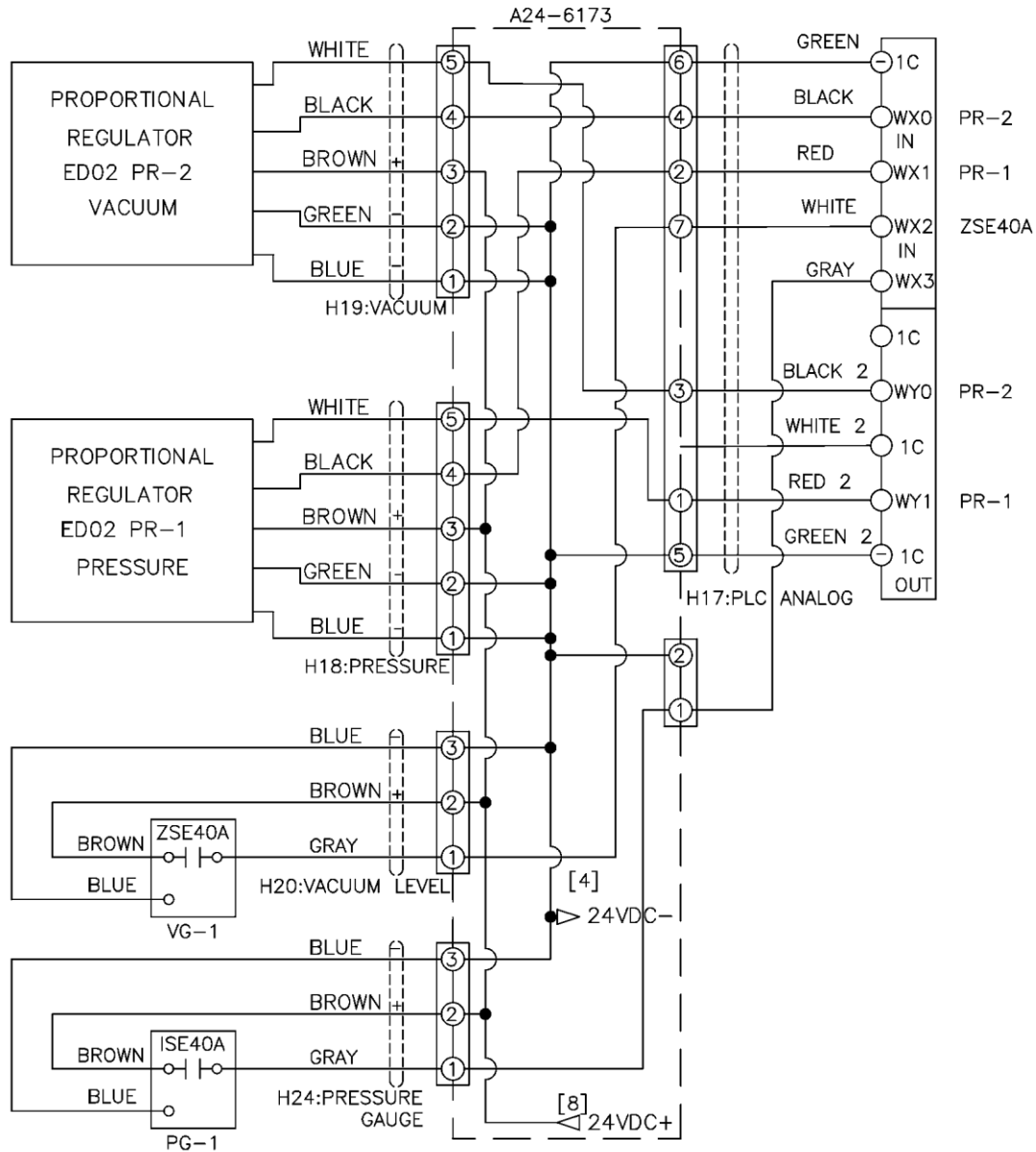

Only qualified technicians should perform this work. Improper installation of the components may result in serious personal injury and damage to equipment. Call PackworldUSA Ltd if further information is needed.